

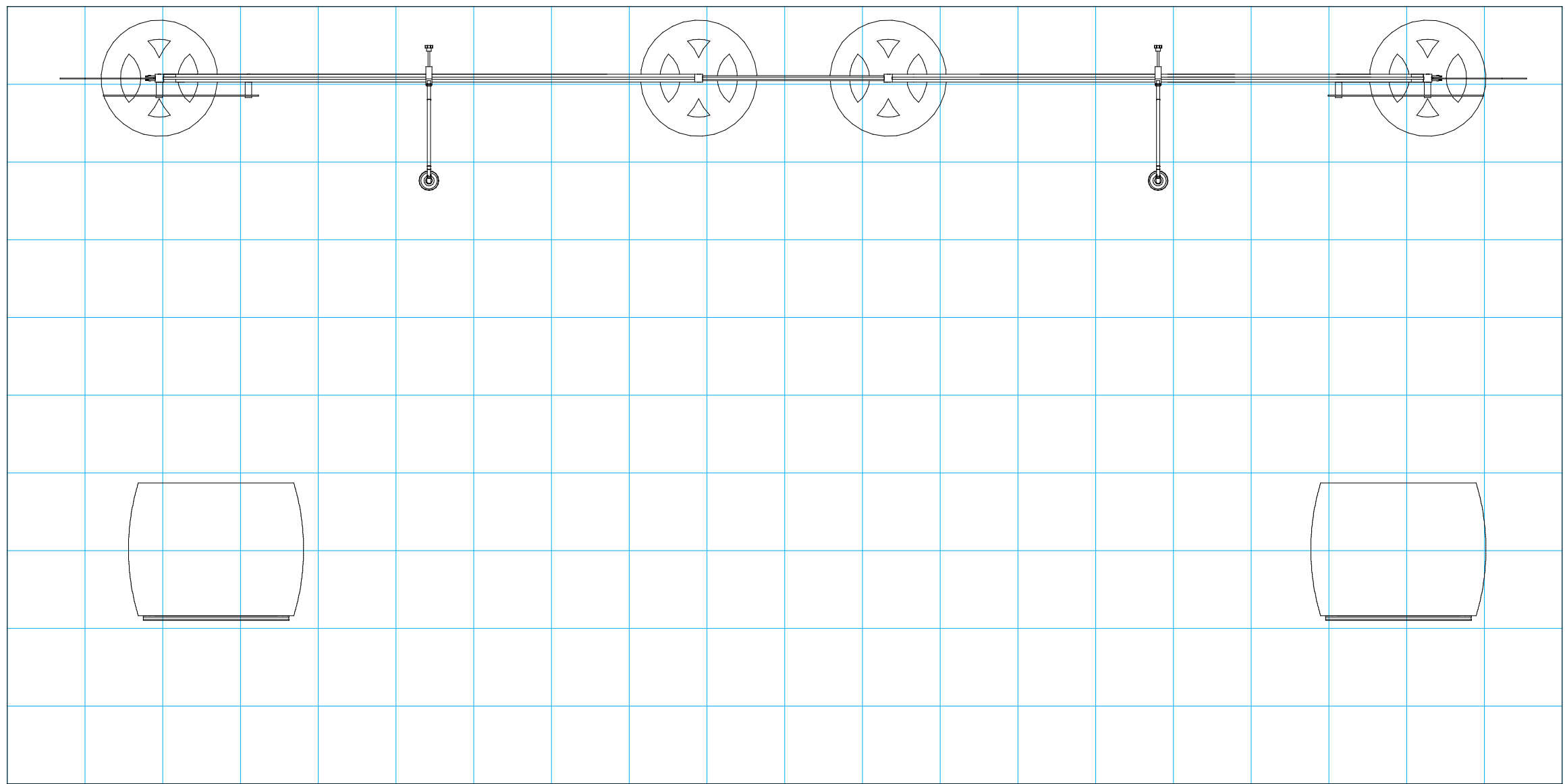

SETUP INSTRUCTIONS



 = 1 sq foot

General Setup Instructions

- Read entire setup instruction manual prior to unpacking parts and pieces.
- The setup instructions are created specifically for this configuration.
- Setup instructions are laid out sequentially in steps, including exploded views with detailed explanation for assembly.

Cleaning & Packing

- For Cleaning Metal, Plex, & Laminate Parts: Use a **MILD NON-ABRASIVE** cleanser and soft cloth/paper towel to clean all surfaces.
- Keep exhibit components away from heat and prolonged sun exposure.
Heat and UV exposure will warp and fade components.
- Retain all provided Packing Materials. All provided packing materials are for ease of repacking & component protection.

Disassembly

- For loss prevention, tighten all set screws and locks during disassembly.

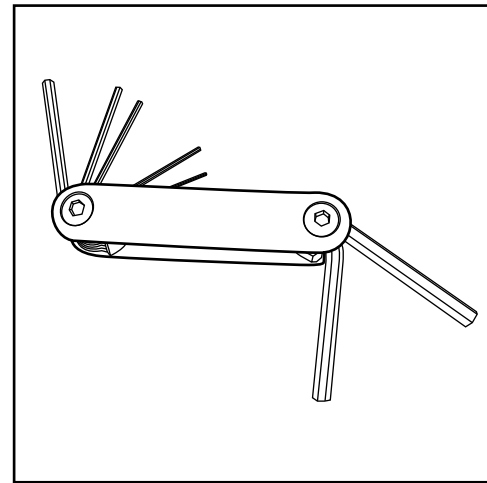

Hex Tool - Essential for Assembly

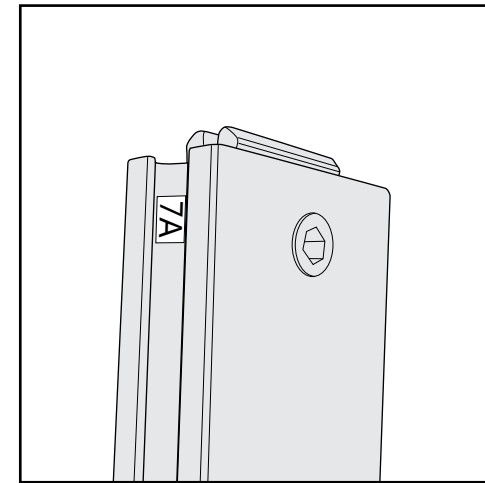

Part Identification - Numbering

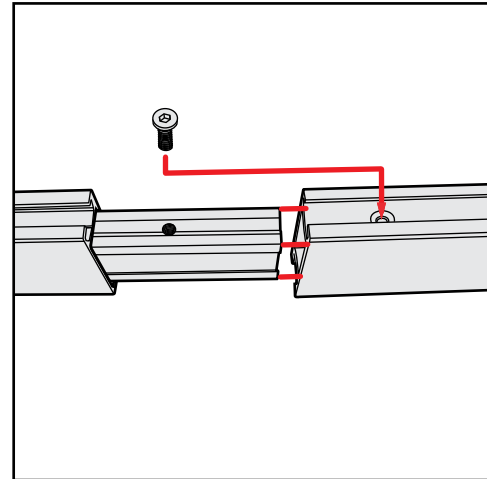

Spline Connection

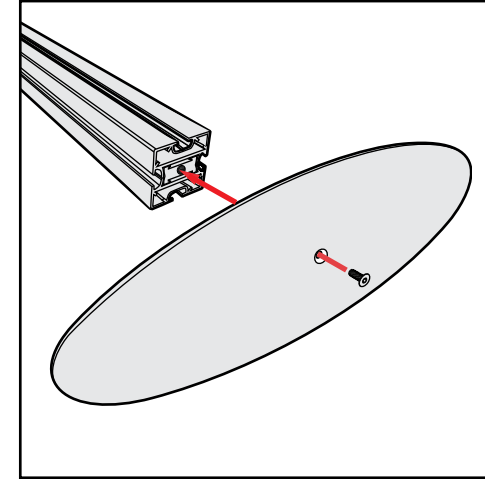

Base Plate & Extrusion Connection

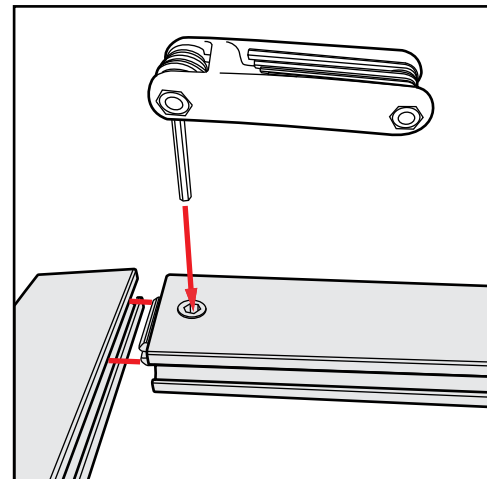

Extrusion & Lock Connection

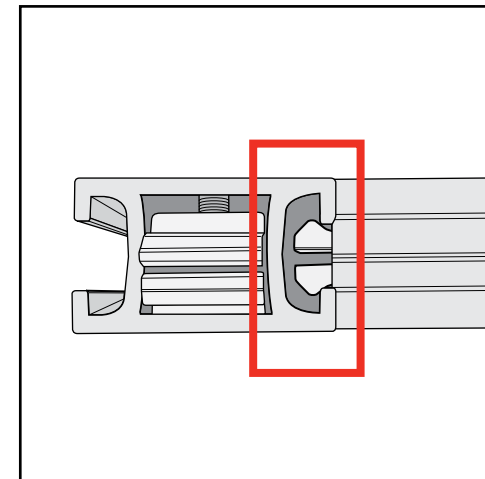

Engaged Lock



WARNING

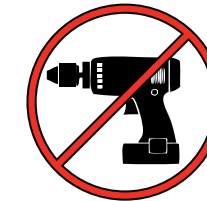

DO NOT USE POWER TOOLS

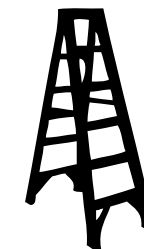

LADDERS OR LIFTS
MAY BE REQUIRED



ALL CONNECTIONS MUST
BE TIGHTLY SECURED

Top View of Each Level

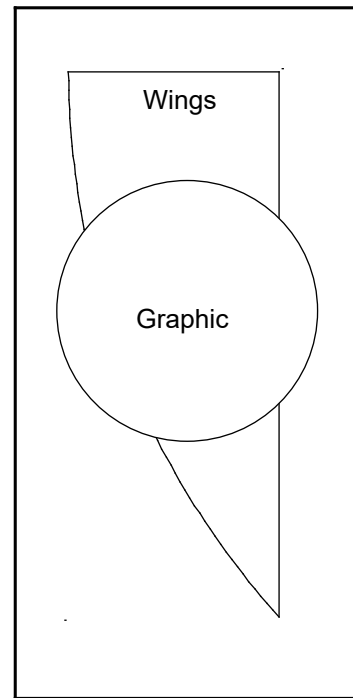

Level 1
(Bottom level)

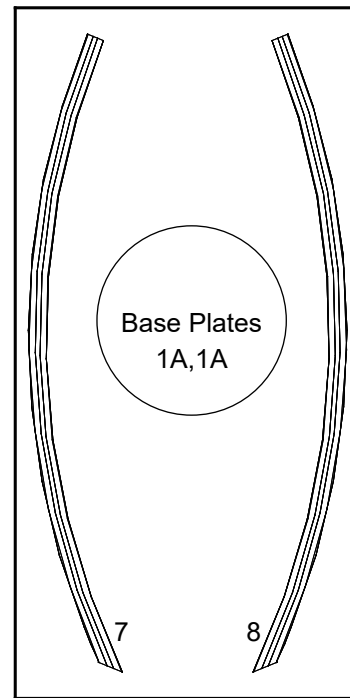

Level 2

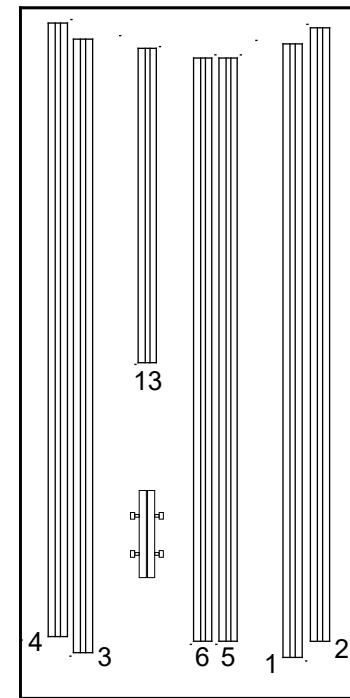

Level 3

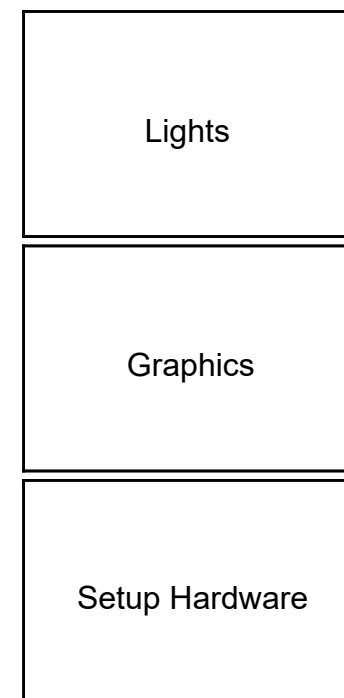

Top View of Each Level

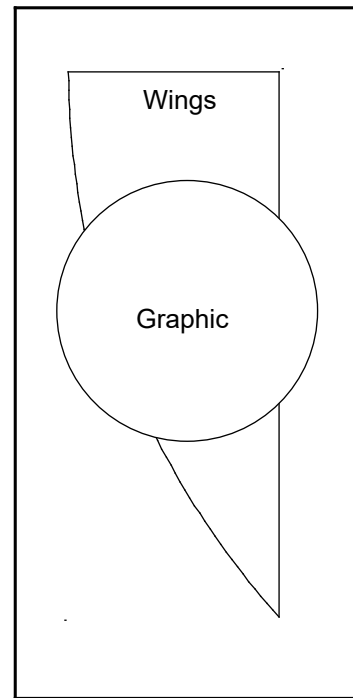

Level 1
(Bottom level)

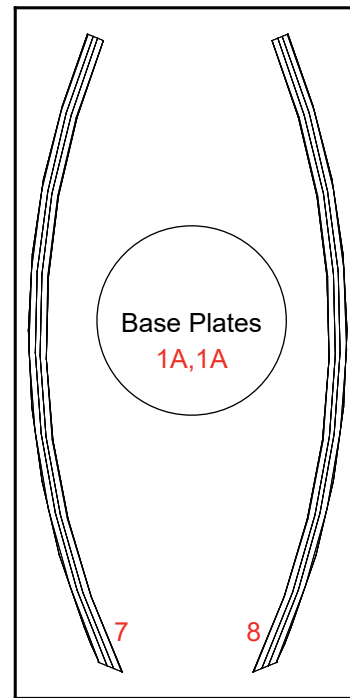

Level 2

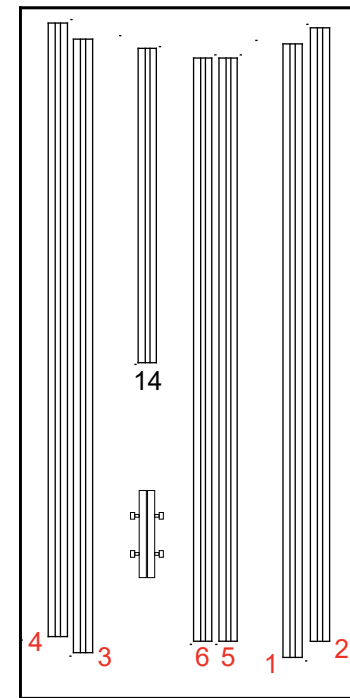

Level 3

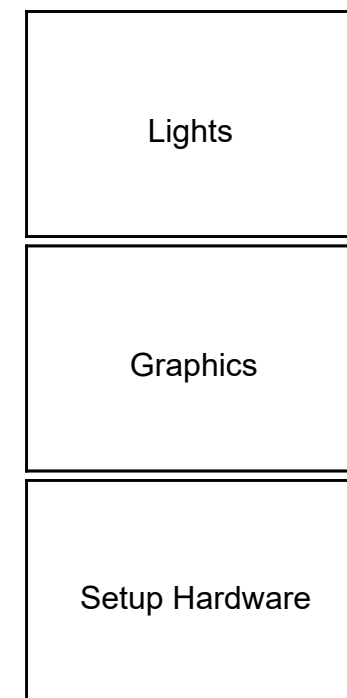

Top View of Each Level

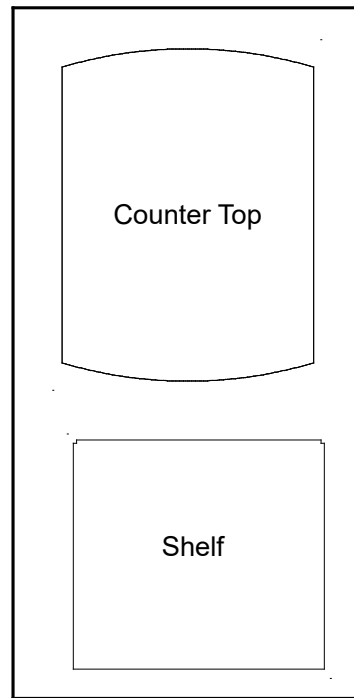

Level 1
(Bottom level)

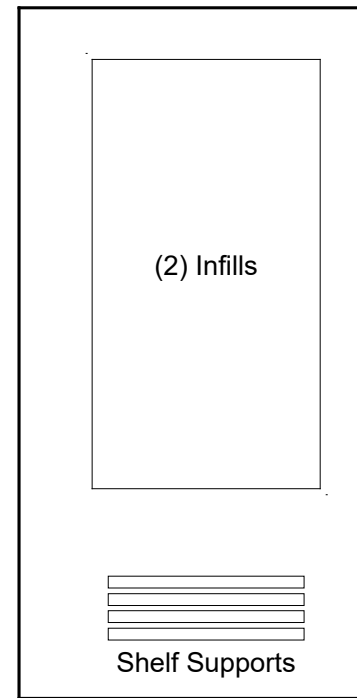

Level 2

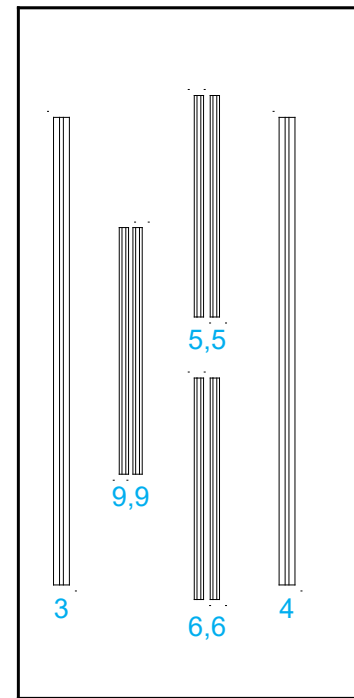

Level 3

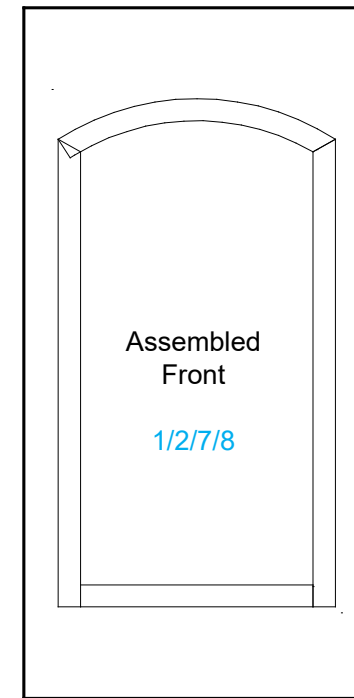

Level 4

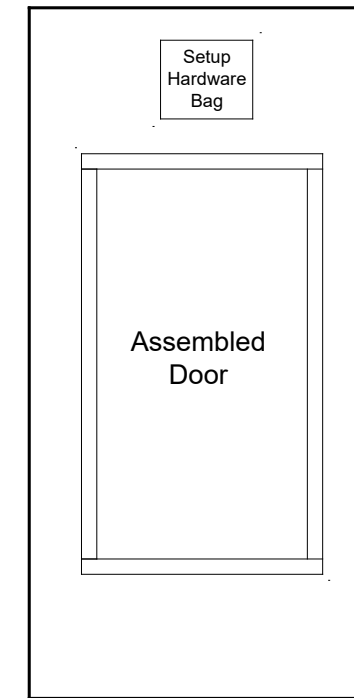

Level 5

Top View of Each Level

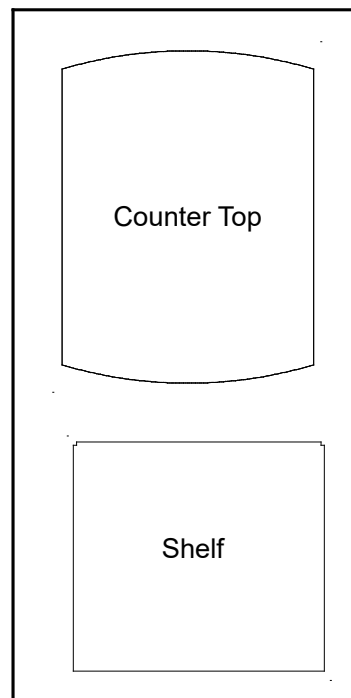

Level 1
(Bottom level)

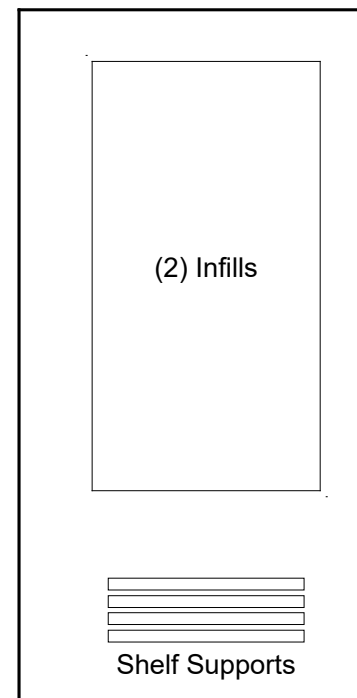

Level 2

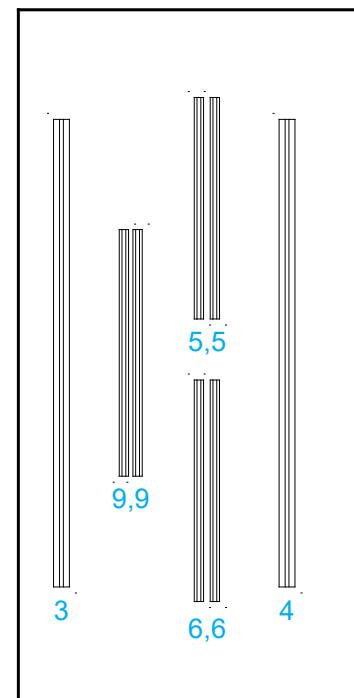

Level 3

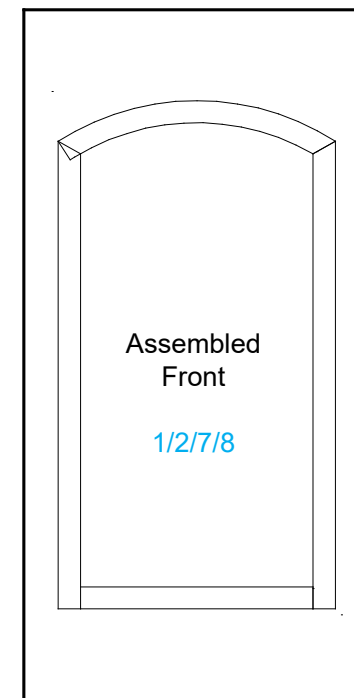

Level 4

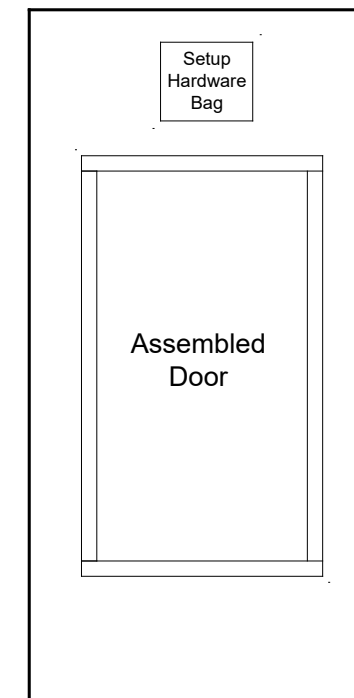

Level 5

Item	Qty.	Description
1A	2	Base Plates
1	1	39" Vertical extrusion
2	1	39" Vertical extrusion top left outside cut
3	1	39" Vertical extrusion
4	1	39" Vertical extrusion top right outside cut
5	1	41" Horizontal extrusion
6	1	41" Horizontal extrusion
7	1	41" Top left curved extrusion
8	1	41" Top right curved extrusion

- Steps:
- 1) Attach base plates [1A] to lower verticals [1,3].
 - 2) Connect upper verticals [2,4] with connection bars [b].
 - 3) Connect horizontals [5,6] with connection bar [a].
 - 4) Connect vertical [1/2,3/4] with horizontal assembly [5/6].
 - 5) Connect curved extrusions [7,8] with connection bar [a].
 - 6) Connect curved assembly [7/8] between verticals [1/2,3/4].
 - 7) Attach Velcro Graphic to back of frame as shown.

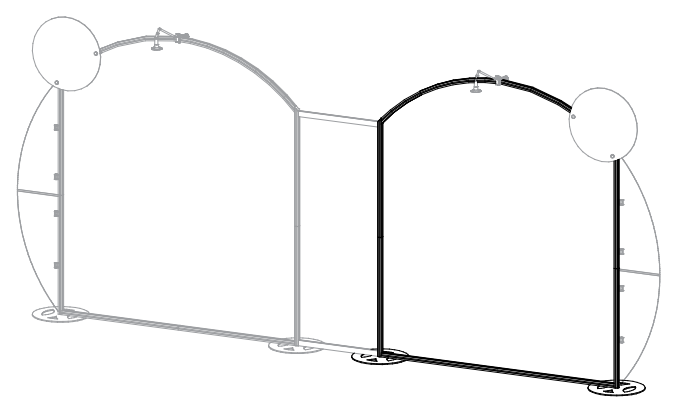

FRONT VIEW

Section Being Assembled is Highlighted in BLACK

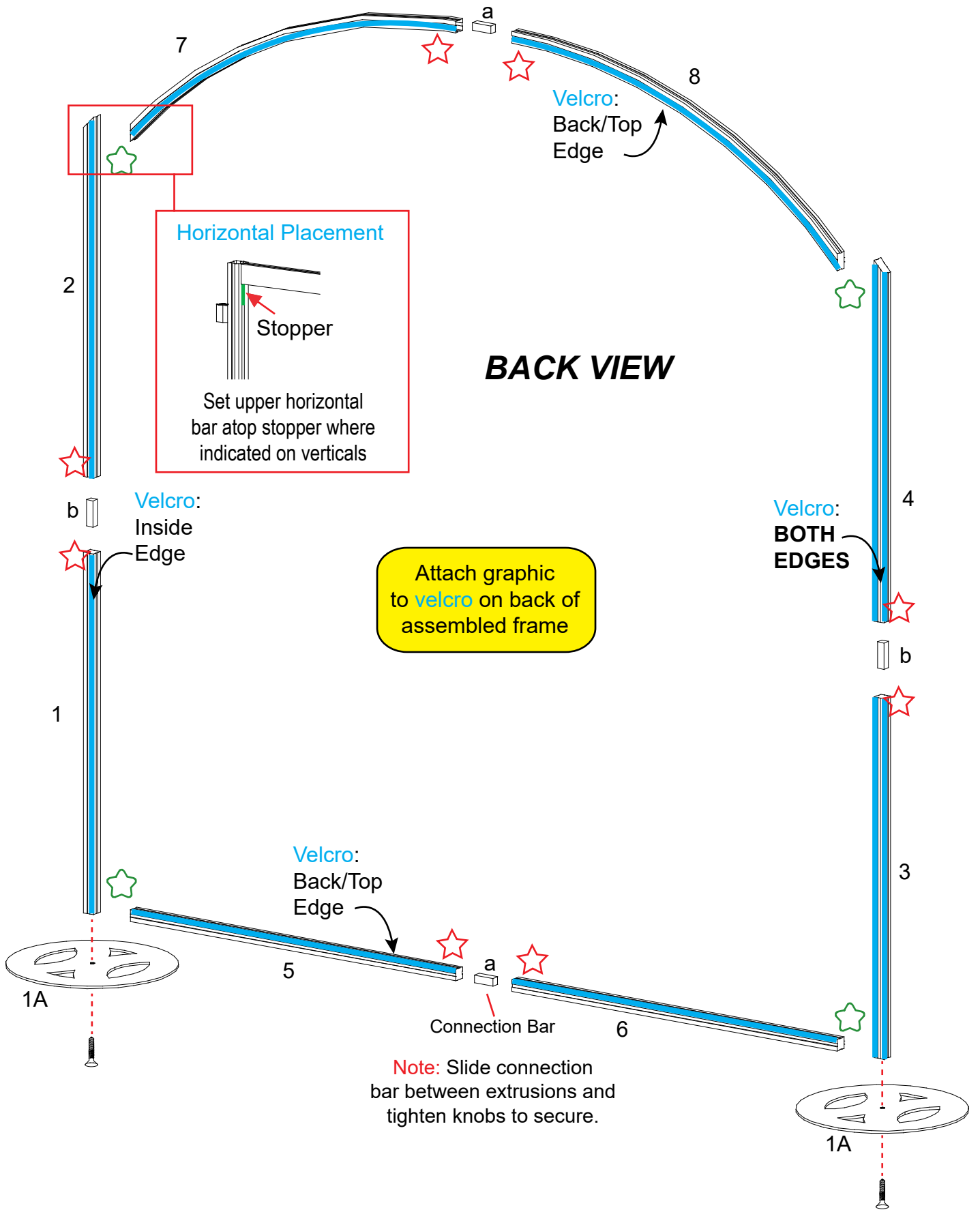

BACK VIEW

Attach graphic to velcro on back of assembled frame

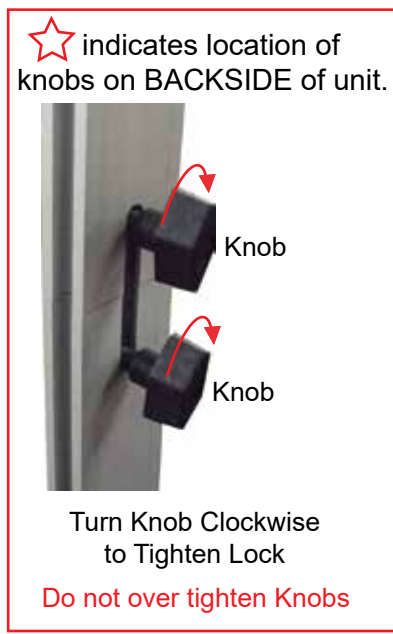

Note: Slide connection bar between extrusions and tighten knobs to secure.

BACK VIEW

Item	Qty.	Description
1A	2	Base Plates
1	1	39" Vertical extrusion
2	1	39" Vertical extrusion top left outside cut
3	1	39" Vertical extrusion
4	1	39" Vertical extrusion top right outside cut
5	1	41" Horizontal extrusion
6	1	41" Horizontal extrusion
7	1	41" Top left curved extrusion
8	1	41" Top right curved extrusion

- Steps:
- 1) Attach base plates [1A] to lower verticals [1,3].
 - 2) Connect upper verticals [2,4] with connection bars [b].
 - 3) Connect horizontals [5,6] with connection bar [a].
 - 4) Connect vertical [1/2,3/4] with horizontal assembly [5/6].
 - 5) Connect curved extrusions [7,8] with connection bar [a].
 - 6) Connect curved assembly [7/8] between verticals [1/2,3/4].
 - 7) Attach Velcro Graphic to back of frame as shown.

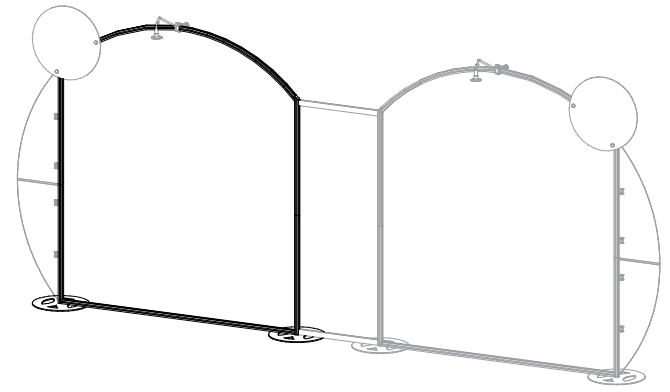

FRONT VIEW

Section Being Assembled is Highlighted in BLACK

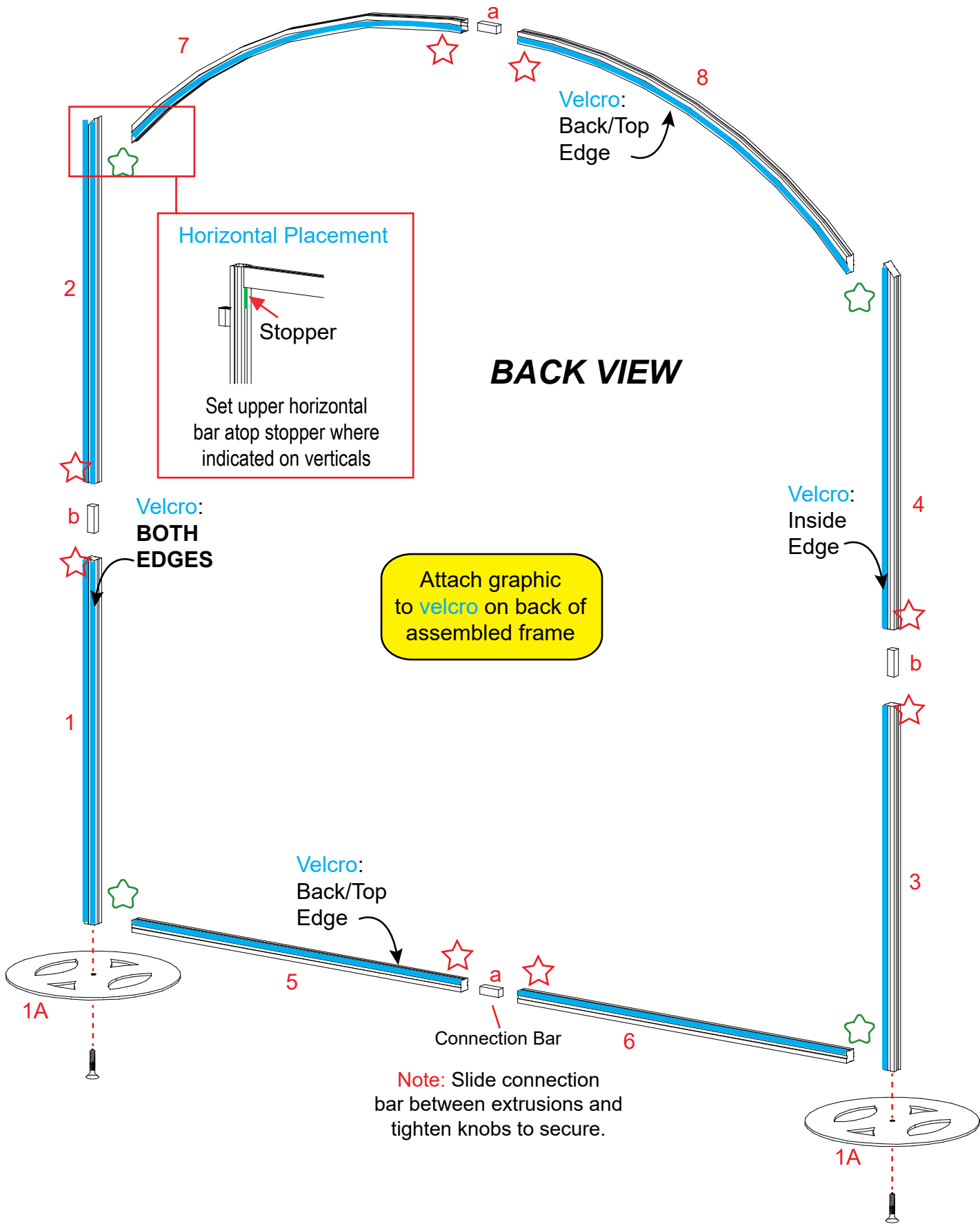

BACK VIEW

BACK VIEW

★ indicates location of knobs on BACKSIDE of unit.

Knob

Knob

Turn Knob Clockwise to Tighten Lock

Do not over tighten Knobs

★ indicates location of connection lock with knob.

Note: Slide connection bar between extrusions and tighten knobs to secure.

Item	Qty.	Description
13	1	28" Horizontal Extrusion
14	1	28" Horizontal Extrusion

- Steps:
- 1) Insert [13,14] between left and right side as shown.
 - 2) Attach Graphics on back of display.

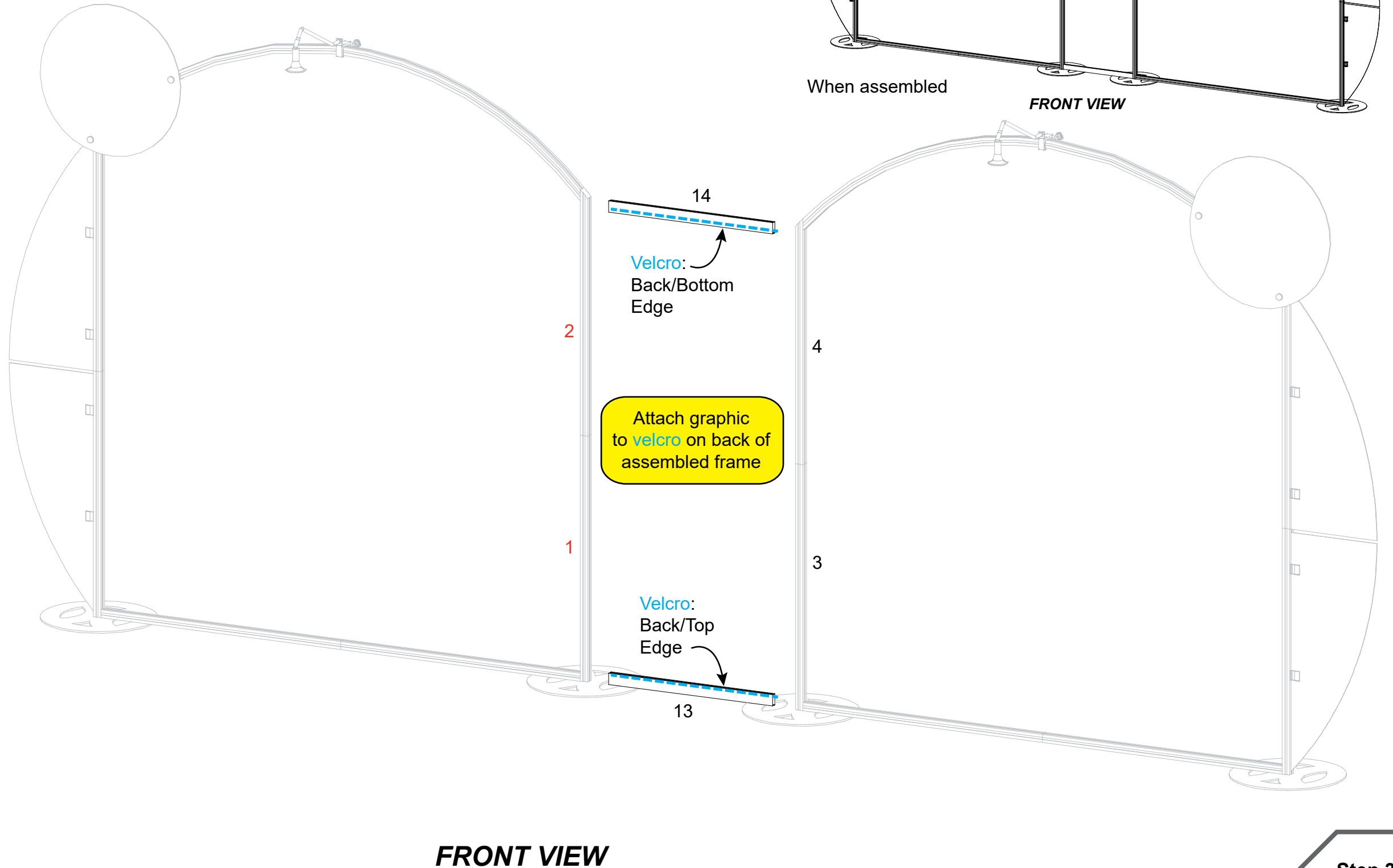

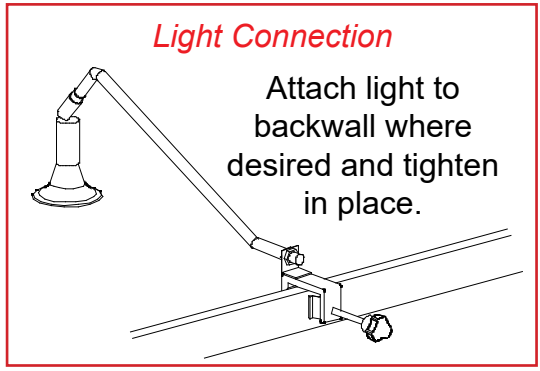
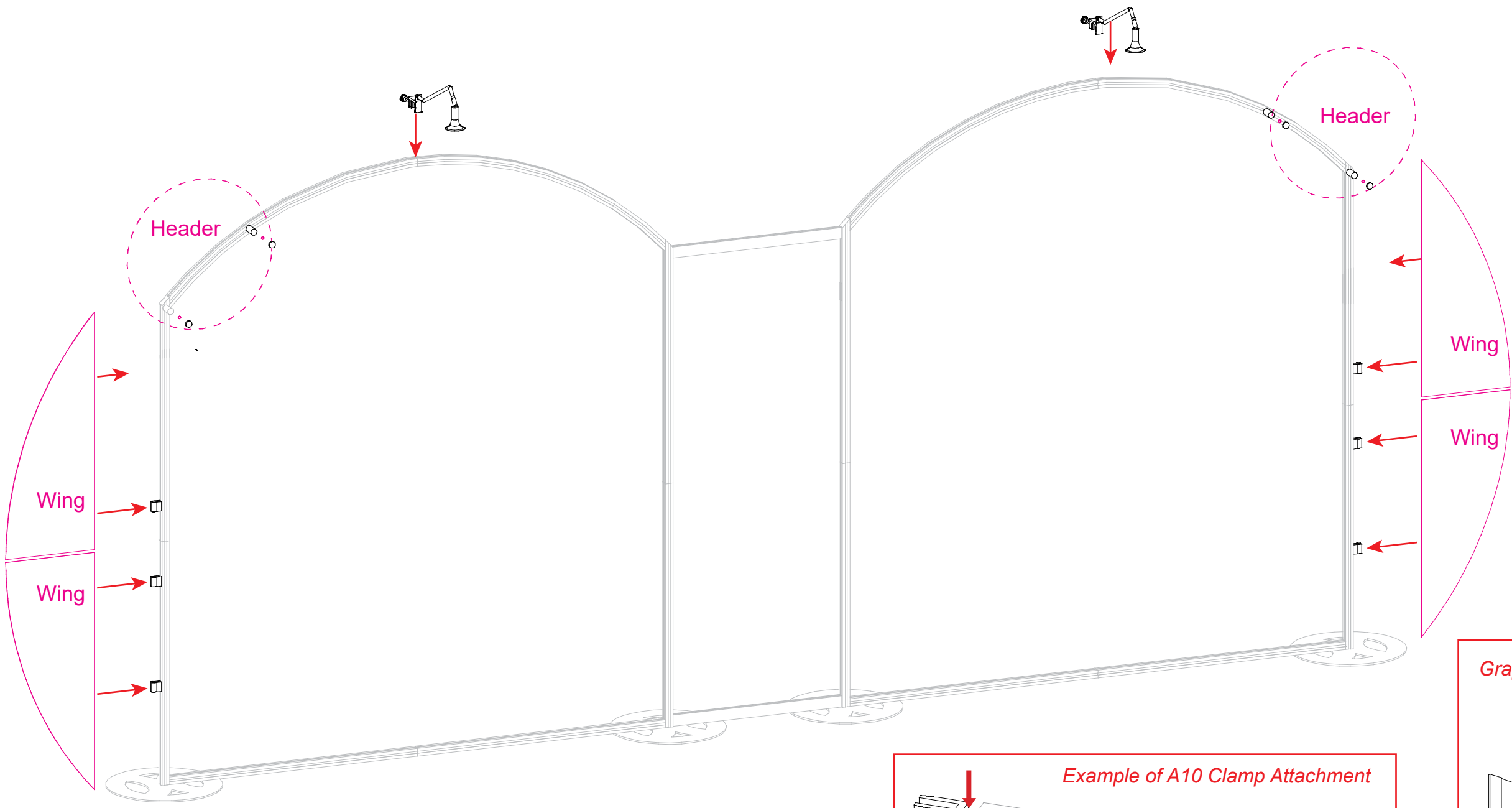

- Steps:
- 1) Attach Wings with to A10's as shown in *Example of A10 Clamp Attachment* detail.
 - 2) Attach header graphic as shown in *Graphic Attachment* detail.
 - 3) Connect lights as shown in *Light Connection* detail.

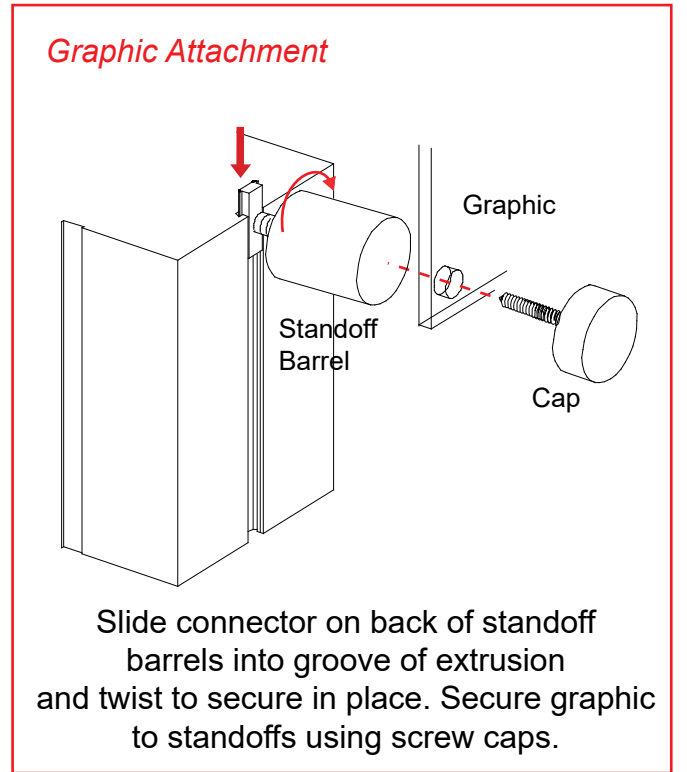
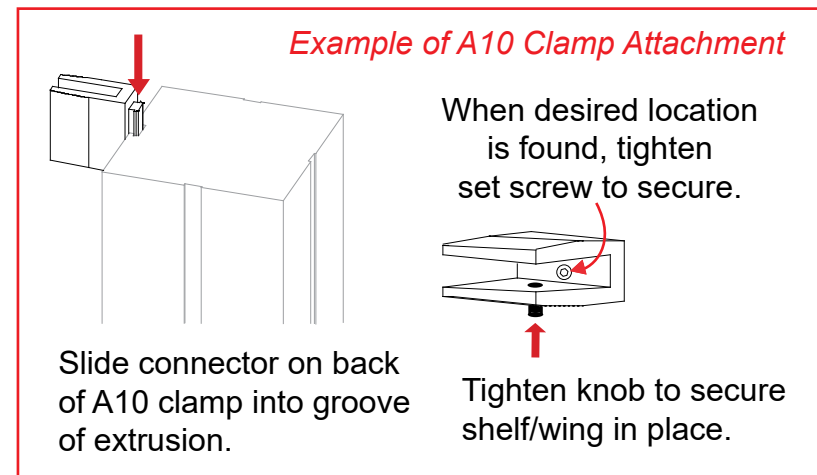

Item	Qty.	Description
1	2	38" Z45 Vertical Extrusion w/ S10
2	2	38" Z45 Vertical Extrusion w/ S10
3	2	38" S40 Vertical Extrusion w/ Door Stop
4	2	38" S40 Vertical Extrusion w/ Door Hinges
5	4	18" Z45 Horizontal Extrusion
6	4	18" Z45 Horizontal Extrusion
7	2	18.917" Z45 Horizontal Extrusion
8	2	20" Z45 Horizontal Extrusion
9	2	22.5" Z45 Curved Extrusion
10	2	18" Z45 Horizontal Extrusion
11	2	18" Z45 Horizontal Extrusion
12	2	20" Z45 Horizontal Extrusion

Steps:

- 1) Attach lower horizontals [5,7,9] between verticals [1,2,3,4].
- 2) Connect door between verticals [3,4]. See **Door Connection** detail.
- 3) Insert infills between verticals [1,2], [1,3], and [1,4].
- 4) Attach upper horizontals [6,8,9] between verticals [1,2,3,4].
- 5) Connect shelf supports to Velcro on infills, then place shelf on top of supports.
- 6) Lock pedestal top to horizontals [6]. See **Pedestal Top Lock** detail.

Repeat steps for other pedestal assembly.

Keep door assembled when packing.

Keep extrusions [1/2/7/8] assembled when packing.

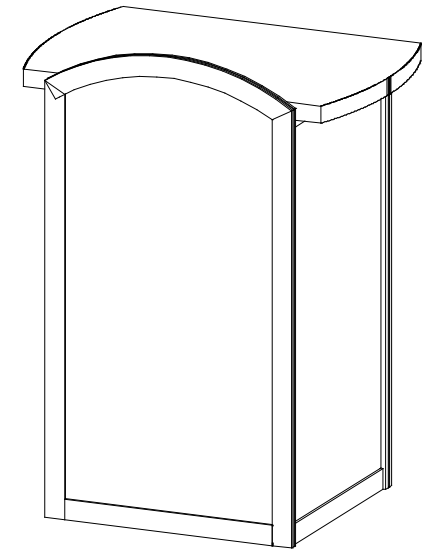
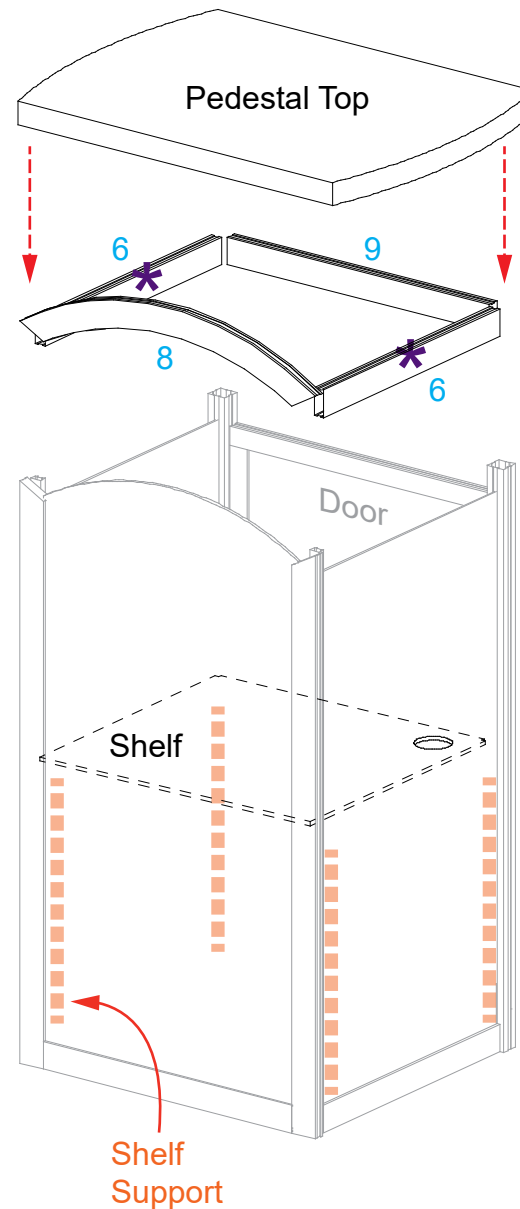
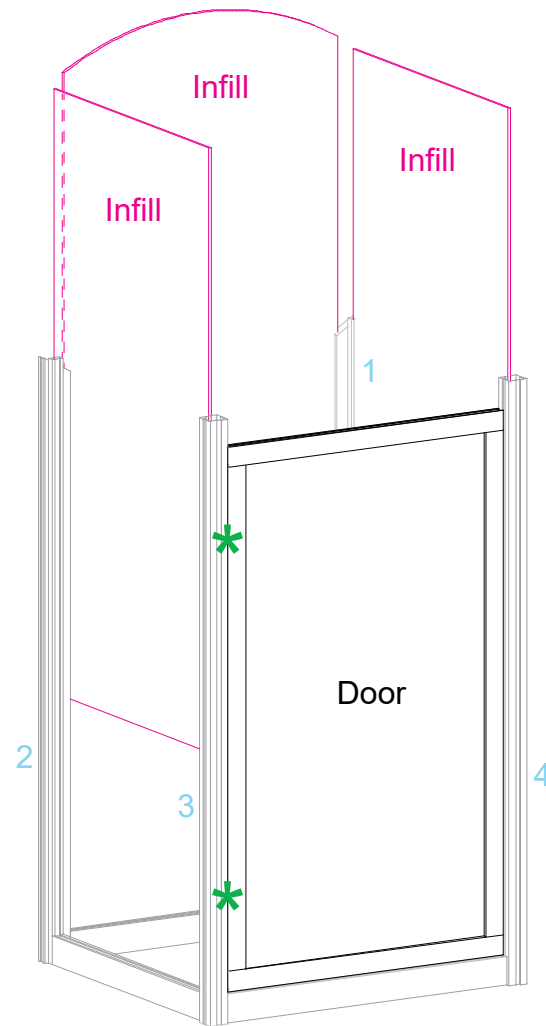
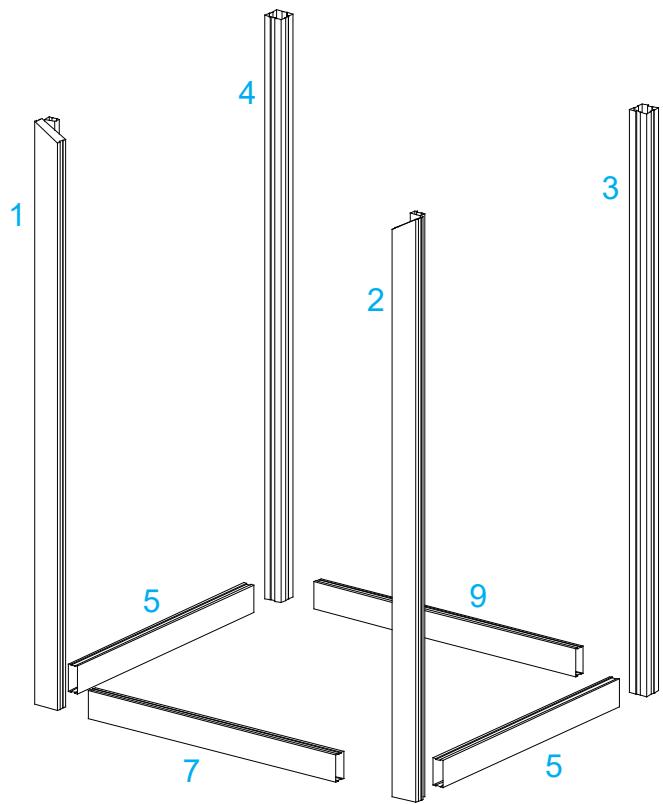

Completed Assembly
Qty. 2

*** Door Connection**

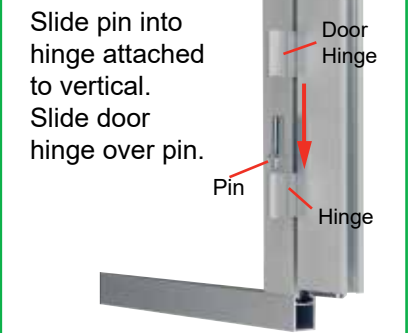

*** Pedestal Top Lock**

